

Notes:
 * Base: Nylon 6T + 30% G.F UL 94V-0
 ,Color Nature
 * Contact: Phosphor Bronze
 * Tab: Brass, with Matte Tin plated
 * For Lead Free IR Reflow Process

ORDERING CODE

CI11 ** M 1 H R0 -LF -ccs
 ① ② ③ ④ ⑤ ⑥ ⑦

- ① Series No.
- ② Contacts:
- ③ M= SMT type header
- ④ Plating:
 1= 100μ" Min. Matte Tin Plated over 50μ" Nickel
 2= Gold flash plated over 1.27μm(50μ") Nickel
- ⑤ Type: H= Right angle
- ⑥ Option: R0= Tape & reel packing (Without pick & place pad) (Standard)
 T0= Tube packing (Without pick & place pad)
- ⑦ LF= For Lead Free IR Processes

Circuit No.1

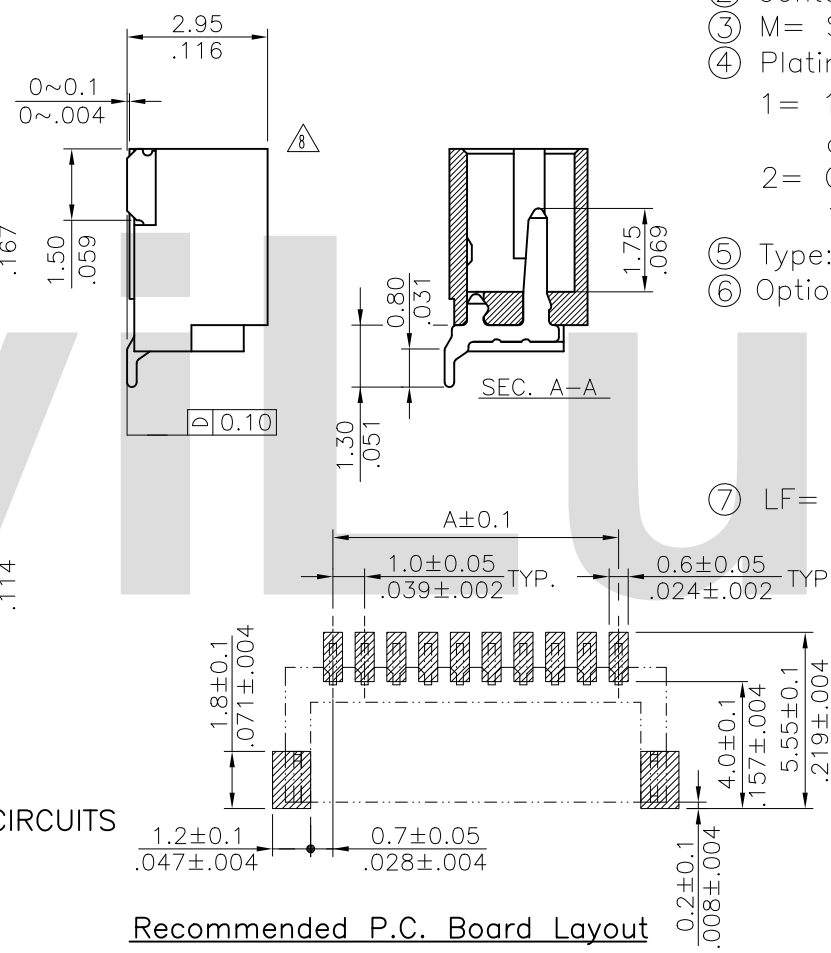
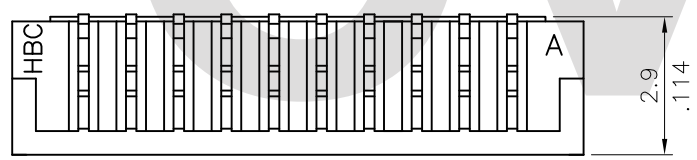
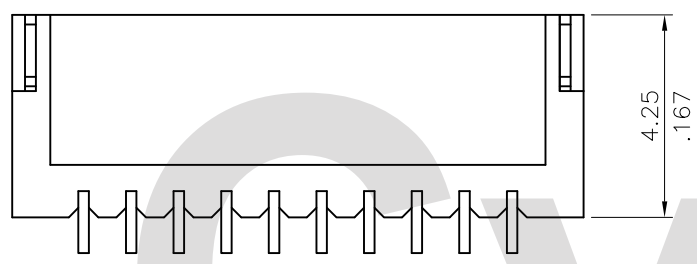

DIM. A = 1.00 x NO. OF SPACES
 DIM. B = DIM. A + 3.0

△ * AVAILABLE IN 2 THROUGH 18,20,24 AND 26 CIRCUITS

Recommended P.C. Board Layout

Lead Free Process
 RoHS Compliant

CVILUX CORP
 2014.02.14
 ISSUED

△12	Sun	1/28-14'	ECNT114016	DATE	UNIT: mm / inch	TITLE: 1.00MM(.079")	 瀚荃股份有限公司 CviLux Corporation
△11	Enya	11/11-13'	ECNT113103/ECRB113027	DRAWN BY: Sun	TOLERANCE UNLESS OTHERWISE SPECIFIED	WIRE TO BOARD CONNECTOR	
△11	Sun	7/05-11'	ECR10039-2/ECN11060	ENGINEER: Eisley	.X ± 0.30/.012 .X' ± 1'	MATERIAL:	
△10	Hank	2/25-09'	ECR09013-0/ECN09078	CHECKED BY: Eisley	.XX ± 0.20/.008 .X' ±	FINISH:	
SYM	NAME	DATE	REVISIONS	APPROVED BY: David	1/29-14'	.XXX ± 0.10/.004 .XX' ±	DRAWING NO. CI1112SN PART NO. CI11**M*H*0-LF-ccs SCALE 6 / 1 SHEET 1 OF 2

NOTE :

- * Reel Material : Corrugated Paper
- * Carrier Material : Clear, Conductive Polystyrene Alloy
- * Cover Tape Material : Polyester
- * Cover Tape Peel Strength : 0.1N - 1.3N
- * Carrier camber is within 1mm in 100mm
- * All dimensions meet EIA-481-2 & EIA-481-3 requirements.
- * Quantity : 1500 PCS/Reel

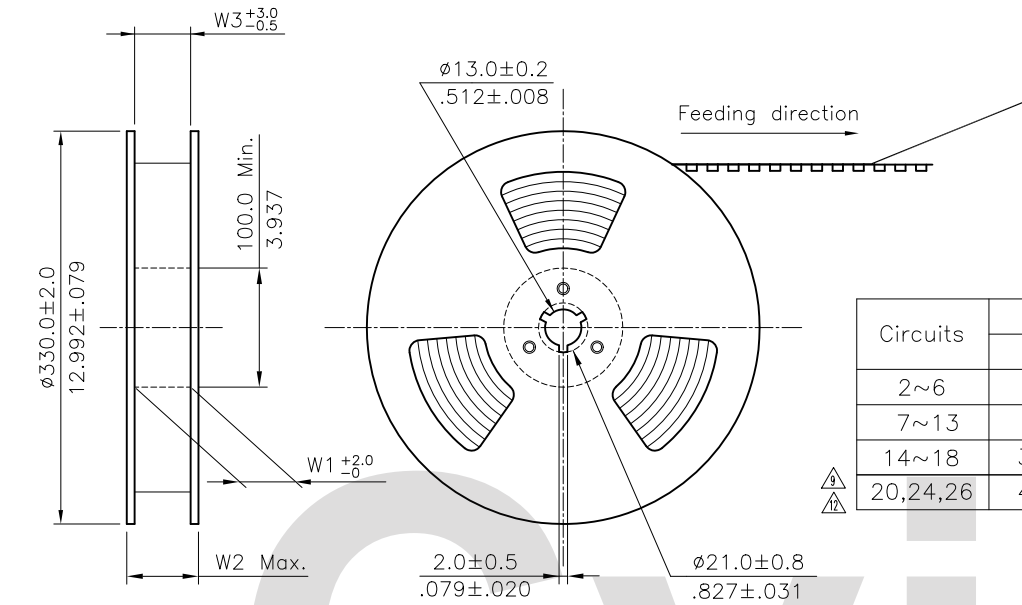

Circuits	Dimension					Packing (Reel/Caton)
	E	F	W1	W2	W3	
2~6	16.0(.630)	-	16.5(.650)	22.5(.886)	16.5(.650)	11
7~13	24.0(.945)	-	24.5(.965)	30.5(1.200)	24.5(.965)	9
14~18	32.0(1.260)	28.40(1.118)	32.5(1.280)	38.5(1.516)	32.5(1.280)	7
20,24,26	44.0(1.732)	40.40(1.596)	44.5(1.752)	50.5(1.988)	44.5(1.752)	5

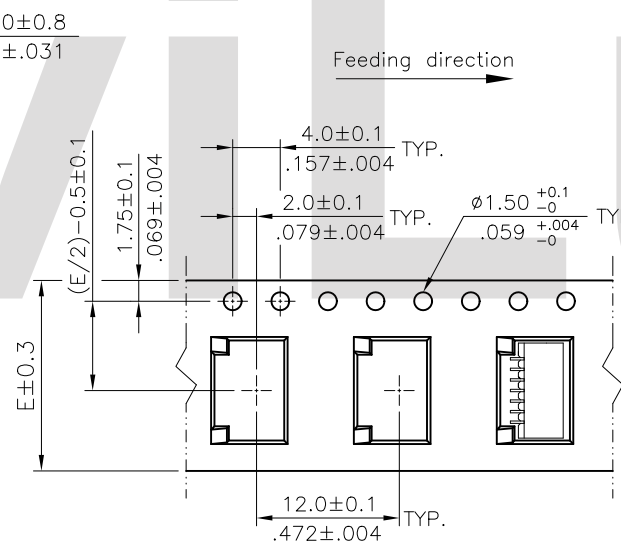
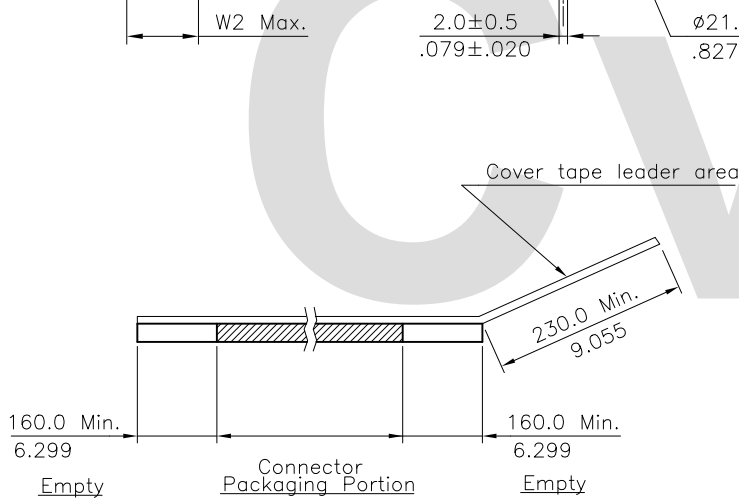

WIDTH : 16.24 mm Carrier

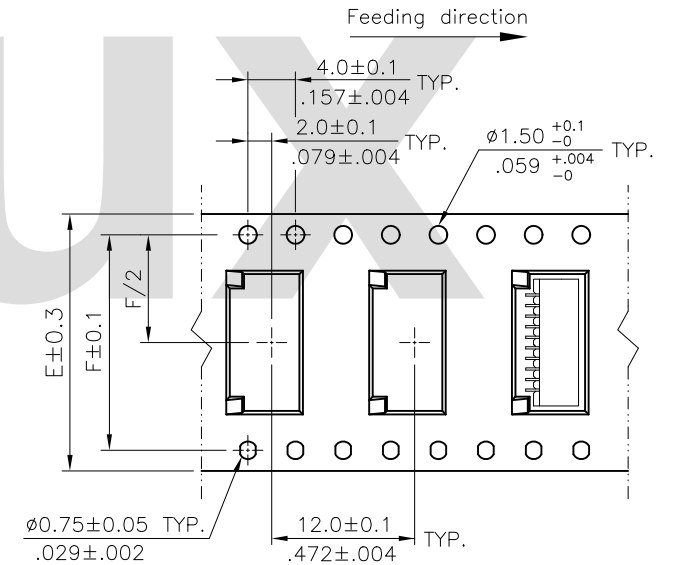

WIDTH : 32.44 mm Carrier

RoHS Compliant

CVILUX CORP
2014.02.14
ISSUED

SYM	NAME	DATE	REVISIONS	APPROVED BY:	DATE	UNIT: mm / inch	TITLE: 1.00MM(.079") WIRE TO BOARD CONNECTOR	MATERIAL:	FINISH:	DRAWING NO. CI1112SN	PART NO. CI11**M*H*0-LF-CCS	SCALE	SHEET 2 OF 2
△12	Sun	1/28-14'	ECNT114016	David	1/29-14'	.X ±	.X' ± 1'						
△11	Enya	11/11-13'	ECNT113103/ECRB113027	Sun	1/28-14'	.XX ±	.X' ±						
△11	Sun	7/05-11'	ECR10039-2/ECN11060	Eisley	1/29-14'	.XXX ±	.XX' ±						
△10	Hank	2/25-09'	ECR09013-0/ECN09078	Eisley	1/29-14'								

瀚荃股份有限公司
CviLux Corporation