

PROPRIETARY AND CONFIDENTIAL
 THE INFORMATION CONTAINED IN THIS DRAWING IS THE SOLE PROPERTY OF <INSERT COMPANY NAME HERE>. ANY REPRODUCTION IN PART OR AS A WHOLE WITHOUT THE WRITTEN PERMISSION OF <INSERT COMPANY NAME HERE> IS PROHIBITED.

		UNLESS OTHERWISE SPECIFIED:		NAME	DATE	TITLE: DC POWER SUPPLY					
		DIMENSIONS ARE IN INCHES	DRAWN	Lim	03/14				SIZE A DWG. NO. A01.00 REV SCALE: 1:4 WEIGHT: SHEET 1 OF 10		
		TOLERANCES:	CHECKED								
		FRACTIONAL ±	ENG APPR.								
		ANGULAR: MACH ± BEND ±	MFG APPR.								
		TWO PLACE DECIMAL ±	Q.A.								
		THREE PLACE DECIMAL ±	COMMENTS:								
		INTERPRET GEOMETRIC TOLERANCING PER:									
		MATERIAL									
		FINISH									
NEXT ASSY	USED ON										
APPLICATION		DO NOT SCALE DRAWING									

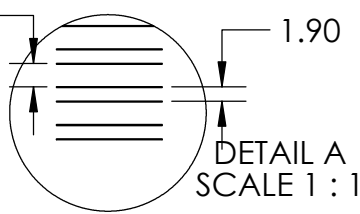
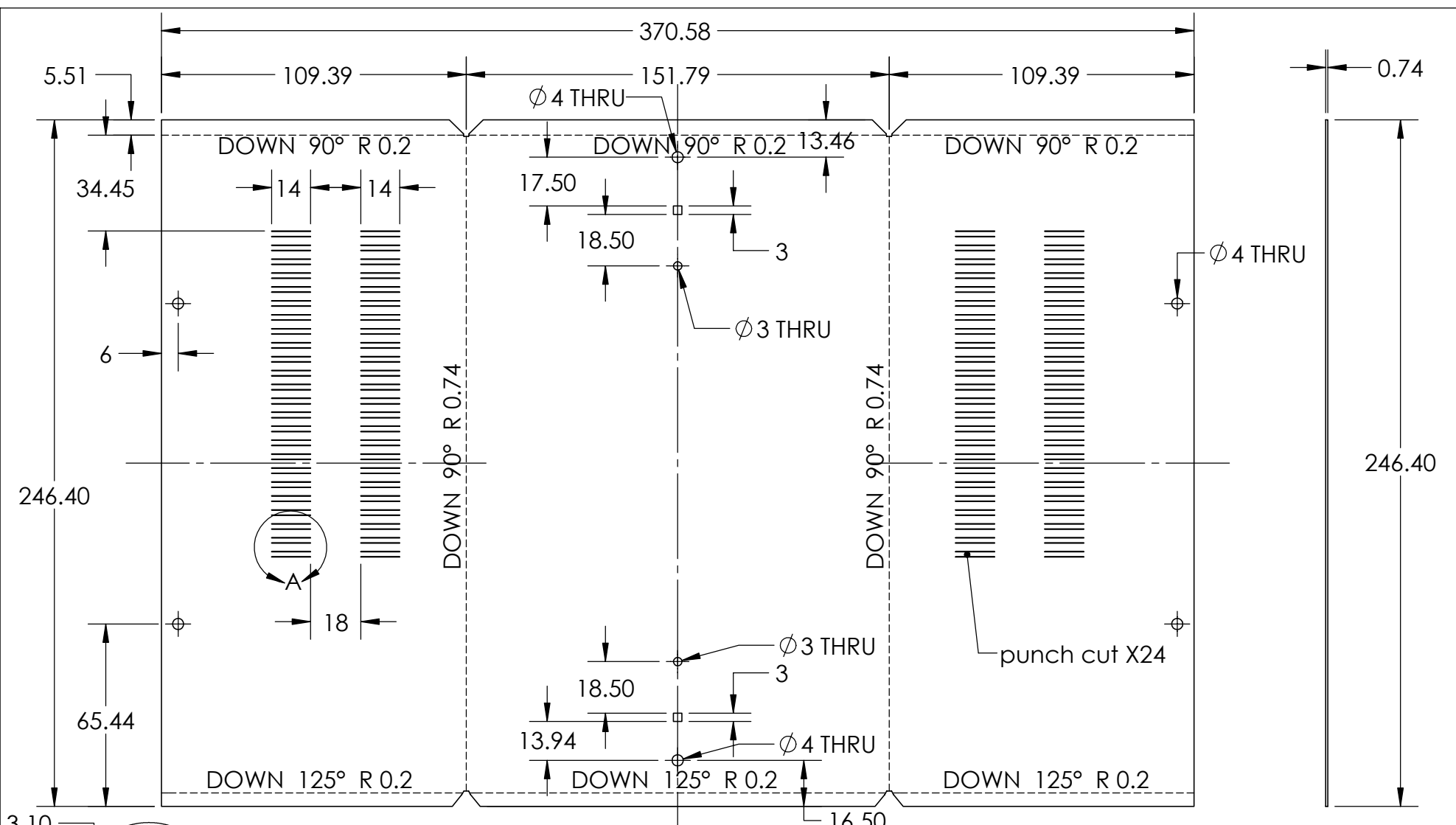

PROPRIETARY AND CONFIDENTIAL
 THE INFORMATION CONTAINED IN THIS DRAWING IS THE SOLE PROPERTY OF <INSERT COMPANY NAME HERE>. ANY REPRODUCTION IN PART OR AS A WHOLE WITHOUT THE WRITTEN PERMISSION OF <INSERT COMPANY NAME HERE> IS PROHIBITED.

		UNLESS OTHERWISE SPECIFIED:		NAME	DATE
		DIMENSIONS ARE IN INCHES		DRAWN	Lim 03/14
		TOLERANCES:		CHECKED	
		FRACTIONAL ±		ENG APPR.	
		ANGULAR: MACH ± BEND ±		MFG APPR.	
		TWO PLACE DECIMAL ±		Q.A.	
		THREE PLACE DECIMAL ±		COMMENTS:	
		INTERPRET GEOMETRIC TOLERANCING PER:			
		MATERIAL			
NEXT ASSY		USED ON			
		FINISH			
APPLICATION		DO NOT SCALE DRAWING			

TITLE:		
PART NO.1 DETAILS (flattened)		
SIZE	DWG. NO.	REV
A	A01.01b	
SCALE: 1:2	WEIGHT:	SHEET 2 OF 10

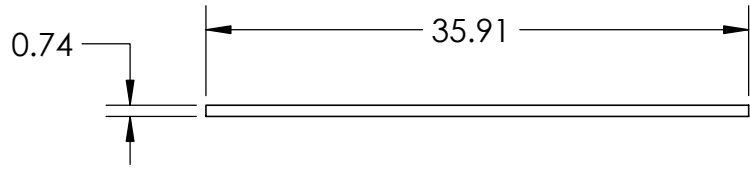
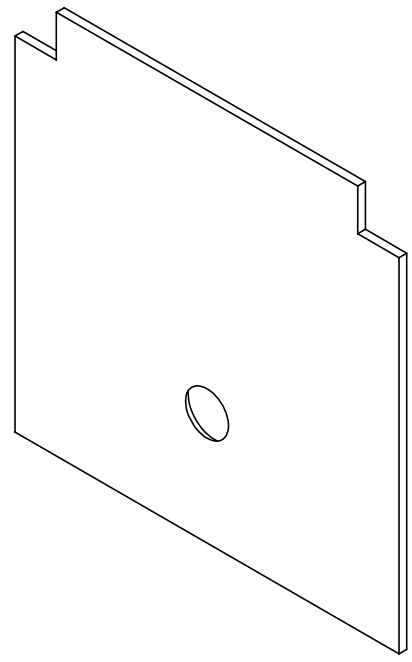
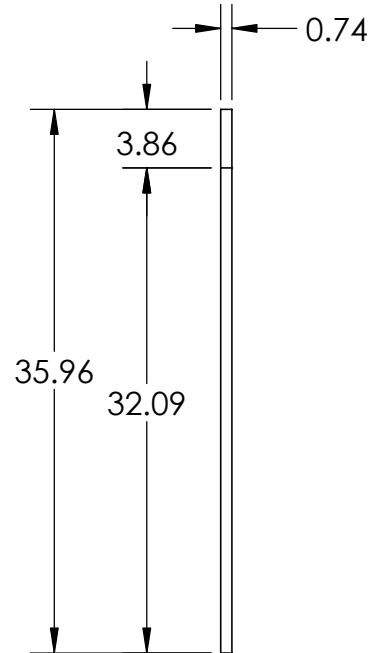
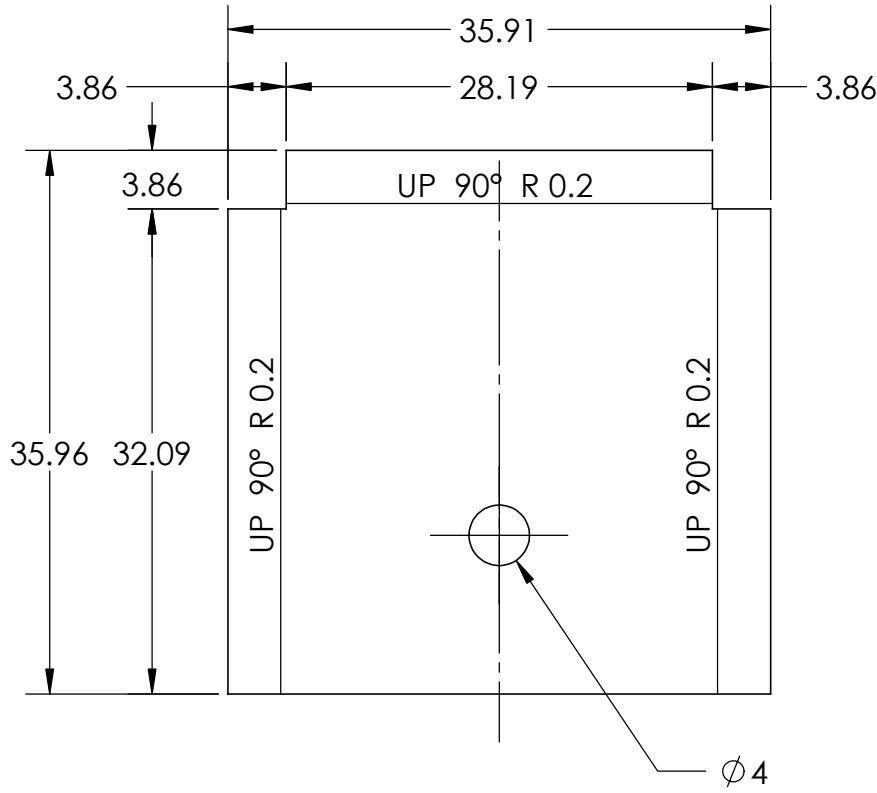

PROPRIETARY AND CONFIDENTIAL
 THE INFORMATION CONTAINED IN THIS DRAWING IS THE SOLE PROPERTY OF <INSERT COMPANY NAME HERE>. ANY REPRODUCTION IN PART OR AS A WHOLE WITHOUT THE WRITTEN PERMISSION OF <INSERT COMPANY NAME HERE> IS PROHIBITED.

		UNLESS OTHERWISE SPECIFIED:		NAME	DATE
		DIMENSIONS ARE IN INCHES	DRAWN	Lim	03/14
		TOLERANCES:	CHECKED		
		FRACTIONAL ±	ENG APPR.		
		ANGULAR: MACH ± BEND ±	MFG APPR.		
		TWO PLACE DECIMAL ±	Q.A.		
		THREE PLACE DECIMAL ±	COMMENTS:		
		INTERPRET GEOMETRIC TOLERANCING PER:			
		MATERIAL			
NEXT ASSY	USED ON	FINISH			
APPLICATION		DO NOT SCALE DRAWING			

TITLE:		
PART NO.2 DETAILS (flattened)		
SIZE	DWG. NO.	REV
A	A01.02b	
SCALE: 2:1	WEIGHT:	SHEET 3 OF 10

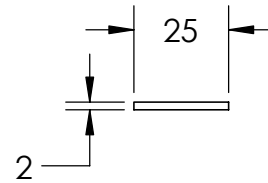
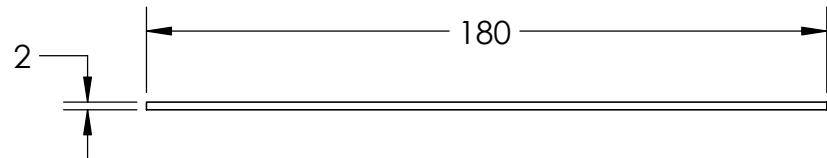
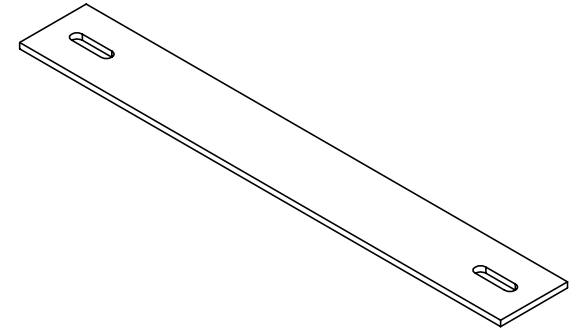
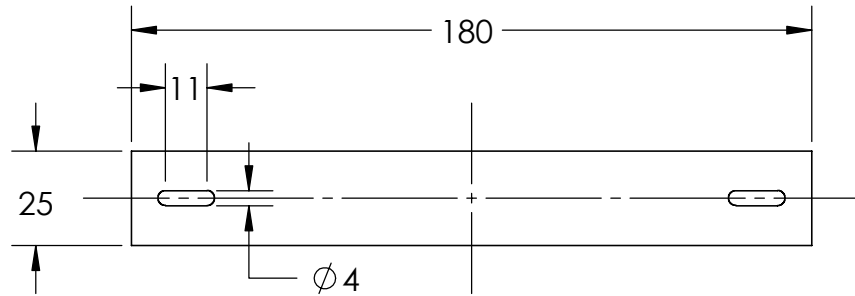

PROPRIETARY AND CONFIDENTIAL
 THE INFORMATION CONTAINED IN THIS DRAWING IS THE SOLE PROPERTY OF <INSERT COMPANY NAME HERE>. ANY REPRODUCTION IN PART OR AS A WHOLE WITHOUT THE WRITTEN PERMISSION OF <INSERT COMPANY NAME HERE> IS PROHIBITED.

		UNLESS OTHERWISE SPECIFIED:		NAME	DATE			
		DIMENSIONS ARE IN INCHES	DRAWN	Lim	03/14	TITLE: PART NO.3 DETAILS		
		TOLERANCES:	CHECKED					
		FRACTIONAL ±	ENG APPR.					
		ANGULAR: MACH ± BEND ±	MFG APPR.					
		TWO PLACE DECIMAL ±	Q.A.			SIZE	DWG. NO.	REV
		THREE PLACE DECIMAL ±	COMMENTS:			A	A01.03	
		INTERPRET GEOMETRIC TOLERANCING PER:				SCALE: 1:2	WEIGHT:	SHEET 4 OF 10
		MATERIAL						
NEXT ASSY	USED ON	FINISH						
APPLICATION		DO NOT SCALE DRAWING						

5

4

3

2

1

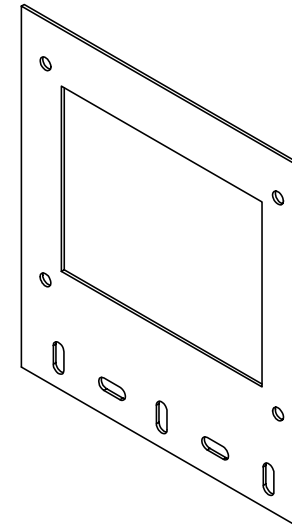
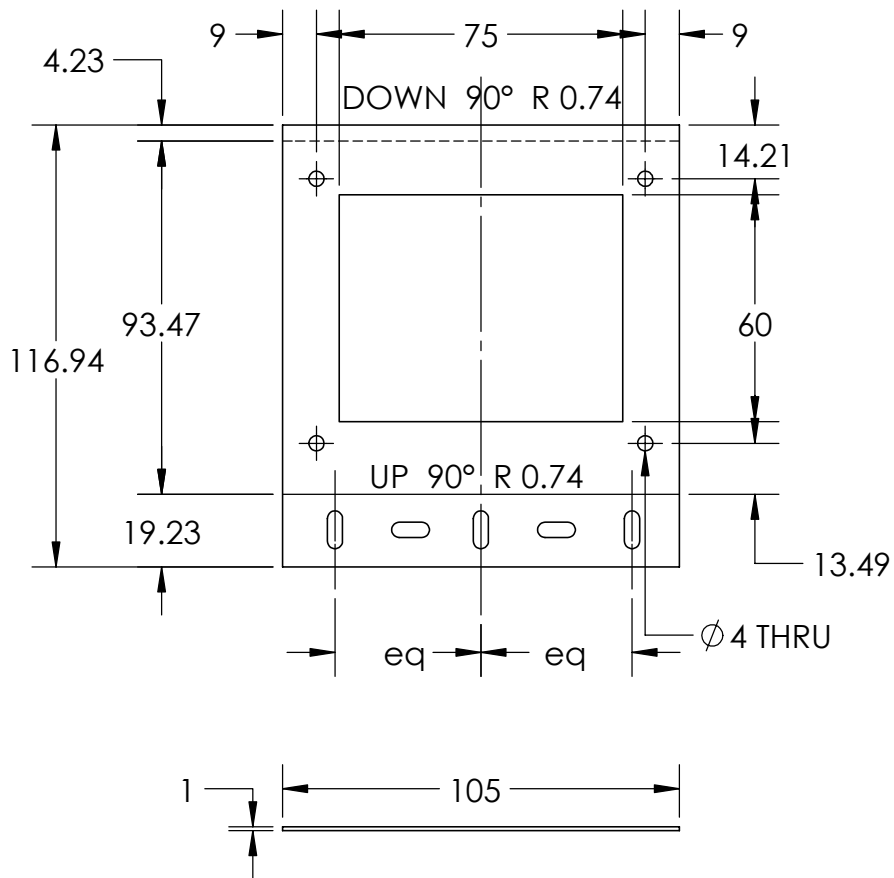

PROPRIETARY AND CONFIDENTIAL
 THE INFORMATION CONTAINED IN THIS DRAWING IS THE SOLE PROPERTY OF <INSERT COMPANY NAME HERE>. ANY REPRODUCTION IN PART OR AS A WHOLE WITHOUT THE WRITTEN PERMISSION OF <INSERT COMPANY NAME HERE> IS PROHIBITED.

		UNLESS OTHERWISE SPECIFIED:		NAME	DATE			
		DIMENSIONS ARE IN INCHES	DRAWN	Lim	03/14	TITLE: PART NO.4 DETAILS (flattened)		
		TOLERANCES: FRACTIONAL ±	CHECKED					
		ANGULAR: MACH ± BEND ±	ENG APPR.					
		TWO PLACE DECIMAL ±	MFG APPR.					
		THREE PLACE DECIMAL ±	Q.A.					
		INTERPRET GEOMETRIC TOLERANCING PER:	COMMENTS:					
		MATERIAL				SIZE	DWG. NO.	REV
		FINISH				A	A01.04b	
NEXT ASSY	USED ON					SCALE: 1:2	WEIGHT:	SHEET 5 OF 10
APPLICATION		DO NOT SCALE DRAWING						

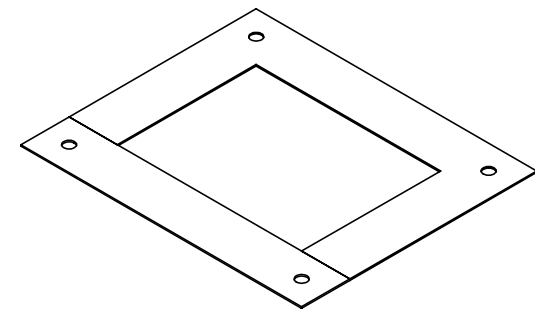
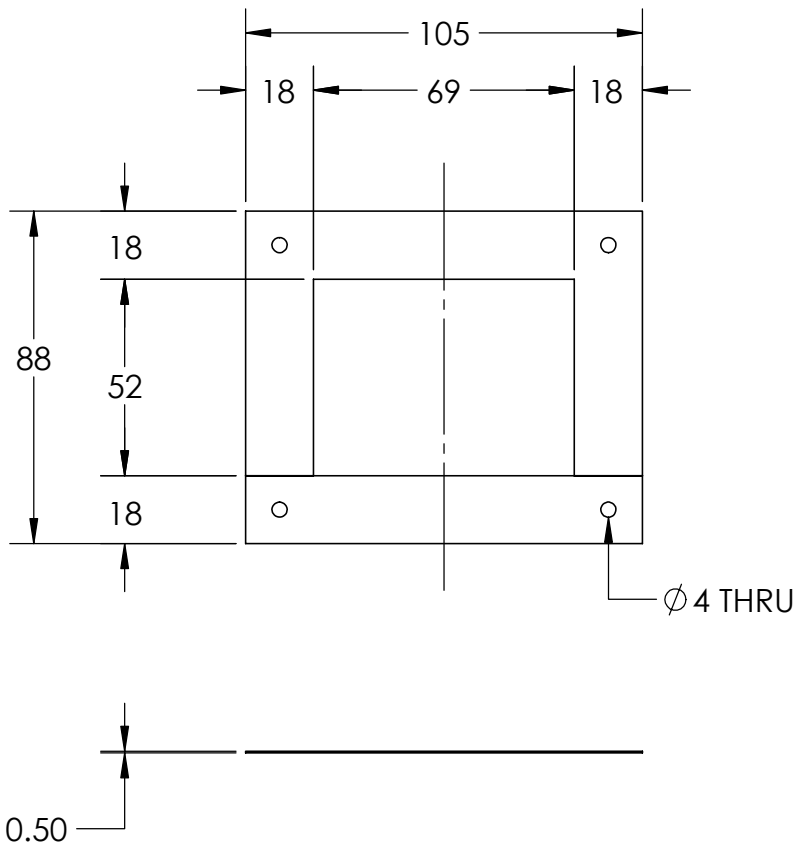

PROPRIETARY AND CONFIDENTIAL
 THE INFORMATION CONTAINED IN THIS DRAWING IS THE SOLE PROPERTY OF <INSERT COMPANY NAME HERE>. ANY REPRODUCTION IN PART OR AS A WHOLE WITHOUT THE WRITTEN PERMISSION OF <INSERT COMPANY NAME HERE> IS PROHIBITED.

		UNLESS OTHERWISE SPECIFIED:		NAME	DATE	TITLE: PART NO.5 DETAILS														
		DIMENSIONS ARE IN INCHES	DRAWN	Lim	03/14				<table border="1"> <tr> <td>SIZE</td> <td>DWG. NO.</td> <td>REV</td> </tr> <tr> <td>A</td> <td>A01.05</td> <td></td> </tr> <tr> <td>SCALE: 1:2</td> <td>WEIGHT:</td> <td>SHEET 6 OF 10</td> </tr> </table>			SIZE	DWG. NO.	REV	A	A01.05		SCALE: 1:2	WEIGHT:	SHEET 6 OF 10
SIZE	DWG. NO.	REV																		
A	A01.05																			
SCALE: 1:2	WEIGHT:	SHEET 6 OF 10																		
		TOLERANCES:	CHECKED																	
		ANGULAR: MACH ± BEND ±	ENG APPR.																	
		TWO PLACE DECIMAL ±	MFG APPR.																	
		THREE PLACE DECIMAL ±	Q.A.			COMMENTS:														
		INTERPRET GEOMETRIC TOLERANCING PER:																		
		MATERIAL																		
NEXT ASSY	USED ON	FINISH																		
APPLICATION		DO NOT SCALE DRAWING																		

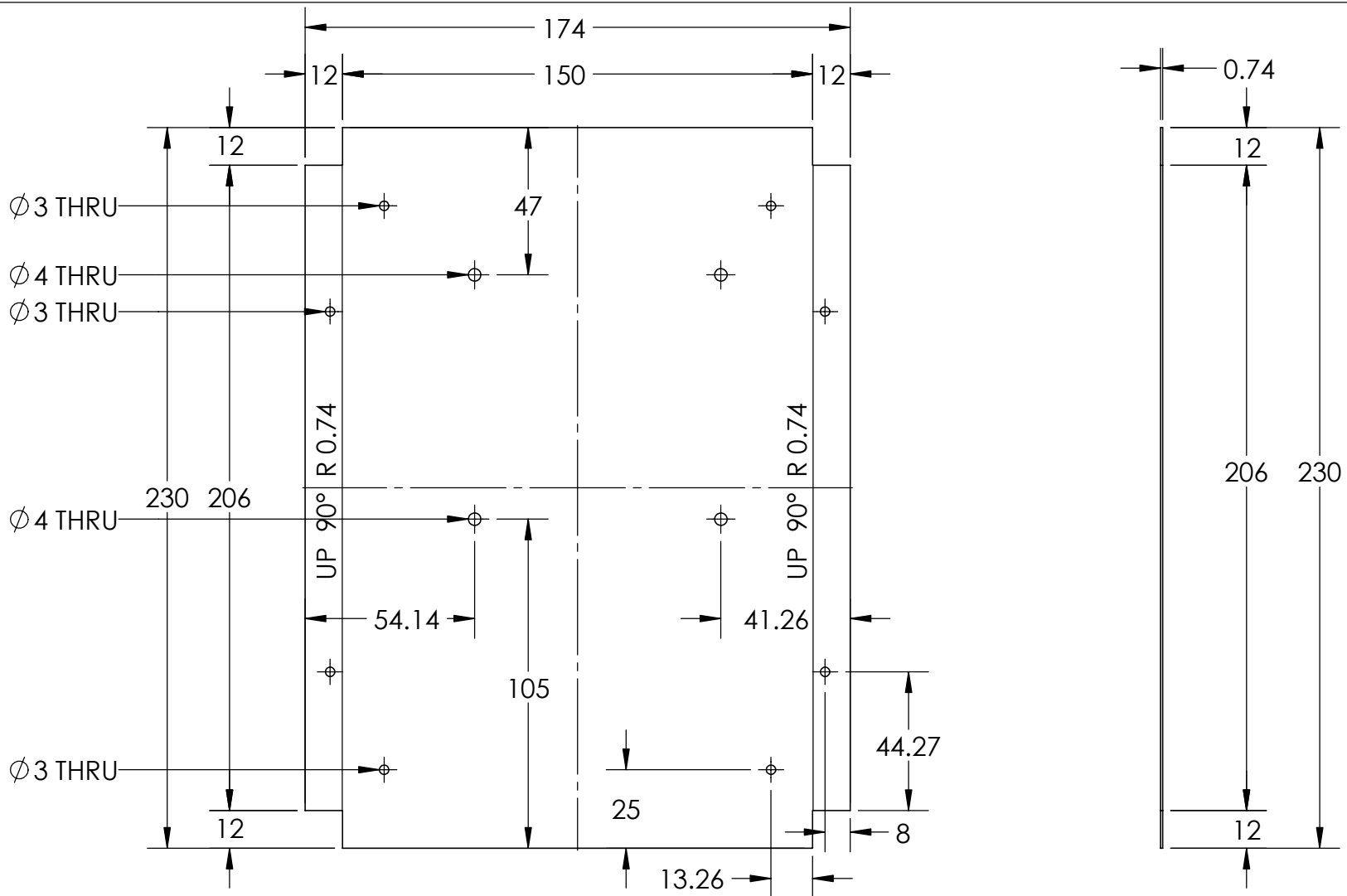

PROPRIETARY AND CONFIDENTIAL
 THE INFORMATION CONTAINED IN THIS DRAWING IS THE SOLE PROPERTY OF <INSERT COMPANY NAME HERE>. ANY REPRODUCTION IN PART OR AS A WHOLE WITHOUT THE WRITTEN PERMISSION OF <INSERT COMPANY NAME HERE> IS PROHIBITED.

		UNLESS OTHERWISE SPECIFIED:		NAME	DATE
		DIMENSIONS ARE IN INCHES	DRAWN	Lim	03/14
		TOLERANCES:	CHECKED		
		FRACTIONAL ±	ENG APPR.		
		ANGULAR: MACH ± BEND ±	MFG APPR.		
		TWO PLACE DECIMAL ±	Q.A.		
		THREE PLACE DECIMAL ±	COMMENTS:		
		INTERPRET GEOMETRIC TOLERANCING PER:			
		MATERIAL			
NEXT ASSY	USED ON	FINISH			
APPLICATION		DO NOT SCALE DRAWING			

TITLE: PART NO.6 DETAILS (flattened)		
SIZE A	DWG. NO. A01.06b	REV
SCALE: 1:2	WEIGHT:	SHEET 7 OF 10

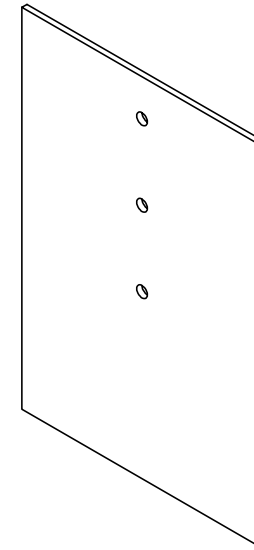
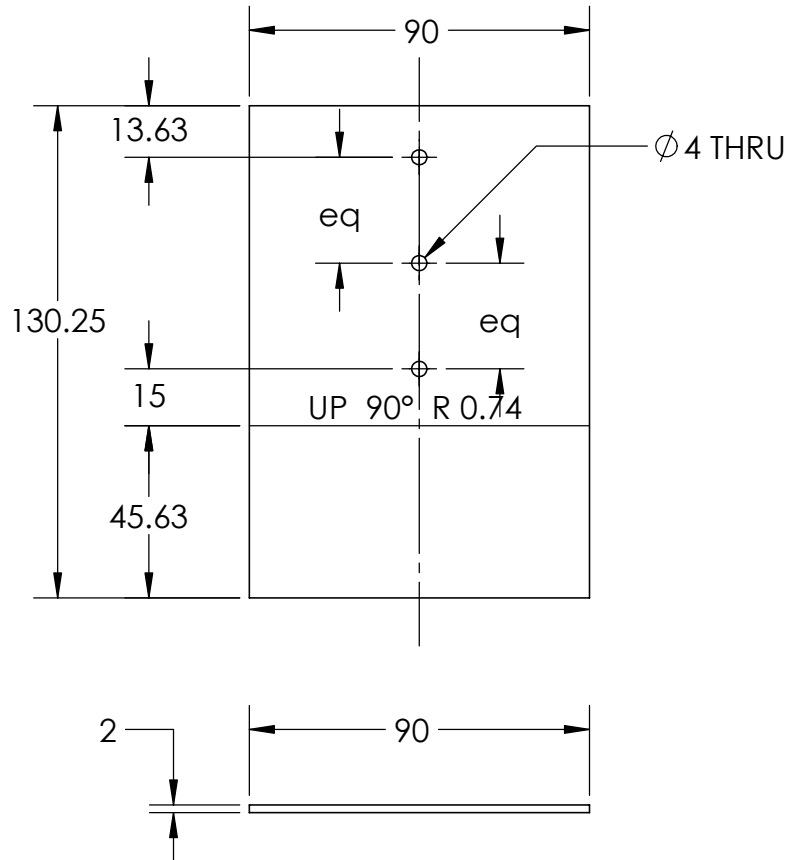

PROPRIETARY AND CONFIDENTIAL
 THE INFORMATION CONTAINED IN THIS DRAWING IS THE SOLE PROPERTY OF <INSERT COMPANY NAME HERE>. ANY REPRODUCTION IN PART OR AS A WHOLE WITHOUT THE WRITTEN PERMISSION OF <INSERT COMPANY NAME HERE> IS PROHIBITED.

		UNLESS OTHERWISE SPECIFIED:		NAME	DATE	TITLE: PART NO.7 DETAILS (flattened)					
		DIMENSIONS ARE IN INCHES TOLERANCES: FRACTIONAL ± ANGULAR: MACH ± BEND ± TWO PLACE DECIMAL ± THREE PLACE DECIMAL ±	DRAWN	Lim	03/14				SIZE A	DWG. NO. A01.07b	REV
		INTERPRET GEOMETRIC TOLERANCING PER:	CHECKED			SCALE: 1:2	WEIGHT:	SHEET 8 OF 10			
NEXT ASSY	USED ON	MATERIAL	ENG APPR.								
APPLICATION		FINISH	MFG APPR.								
		DO NOT SCALE DRAWING	Q.A.								
			COMMENTS:								

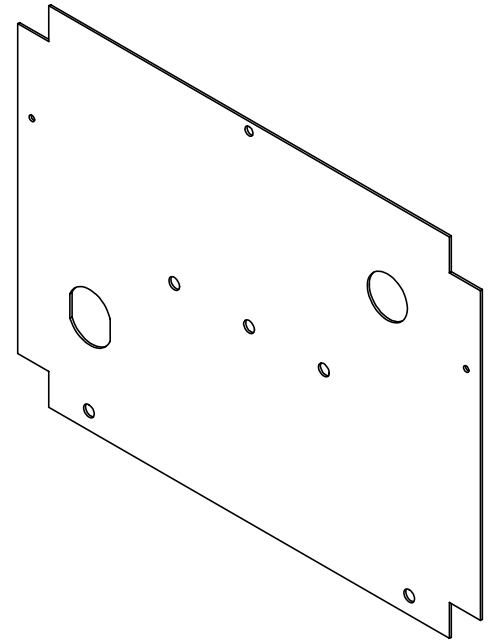
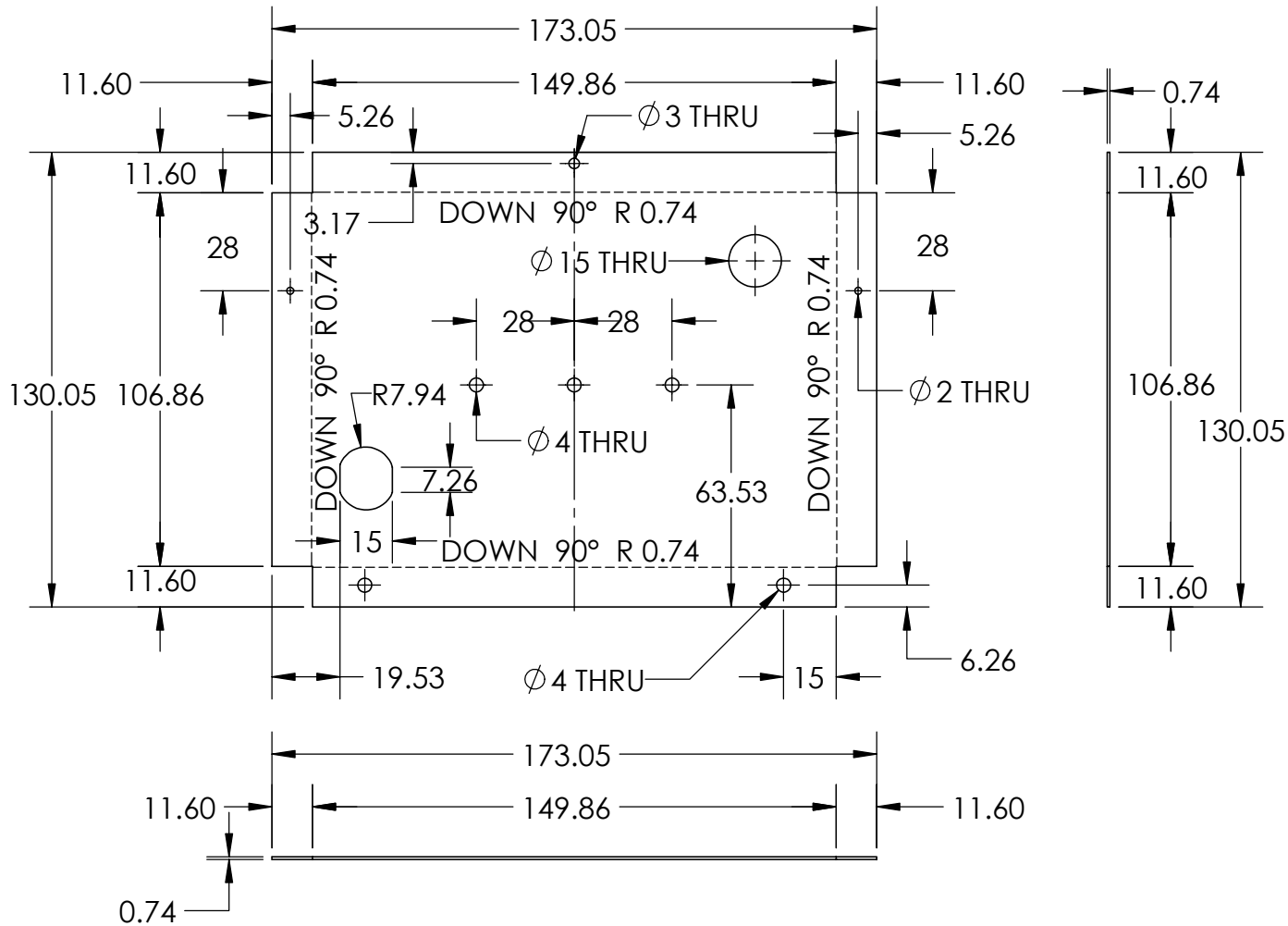

PROPRIETARY AND CONFIDENTIAL
 THE INFORMATION CONTAINED IN THIS DRAWING IS THE SOLE PROPERTY OF <INSERT COMPANY NAME HERE>. ANY REPRODUCTION IN PART OR AS A WHOLE WITHOUT THE WRITTEN PERMISSION OF <INSERT COMPANY NAME HERE> IS PROHIBITED.

		UNLESS OTHERWISE SPECIFIED:		NAME	DATE
		DIMENSIONS ARE IN INCHES	DRAWN	Lim	03/14
		TOLERANCES:	CHECKED		
		FRACTIONAL ±	ENG APPR.		
		ANGULAR: MACH ± BEND ±	MFG APPR.		
		TWO PLACE DECIMAL ±	Q.A.		
		THREE PLACE DECIMAL ±	COMMENTS:		
		INTERPRET GEOMETRIC TOLERANCING PER:			
		MATERIAL			
NEXT ASSY	USED ON	FINISH			
APPLICATION		DO NOT SCALE DRAWING			

TITLE: PART NO.8 DETAILS (flattened)		
SIZE A	DWG. NO. A01.08b	REV
SCALE: 1:2	WEIGHT:	SHEET 9 OF 10

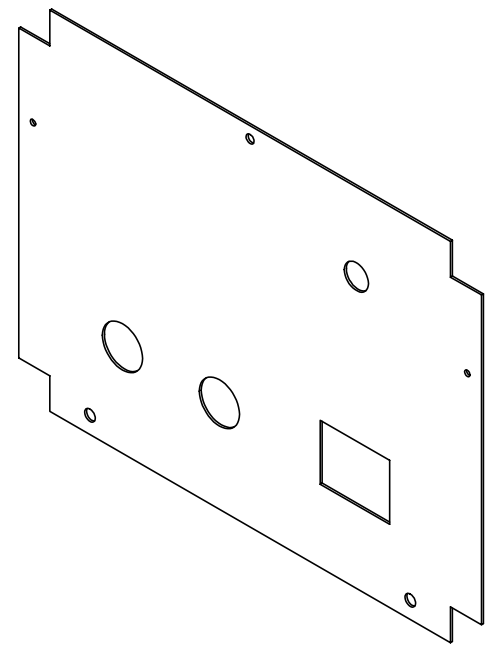
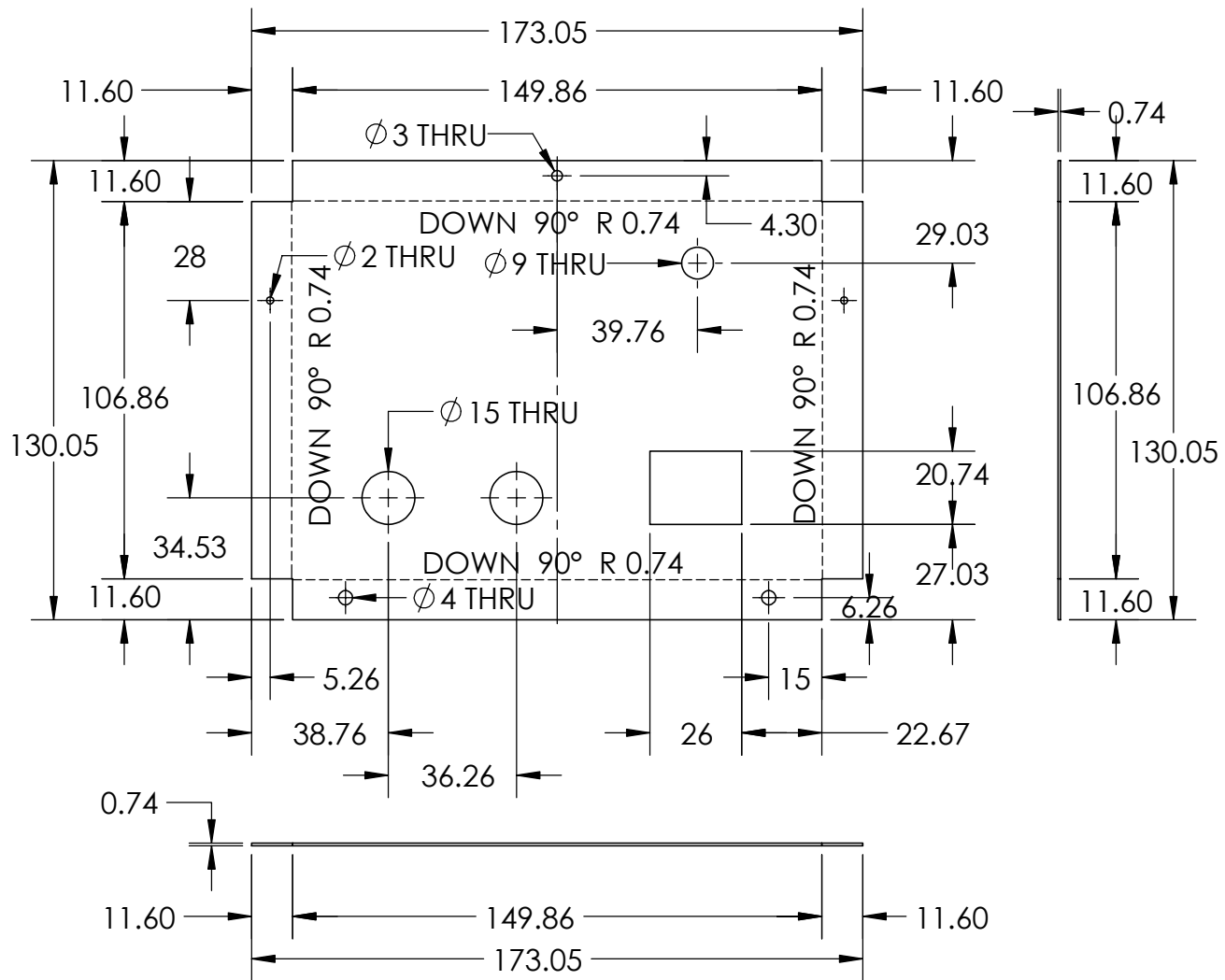

PROPRIETARY AND CONFIDENTIAL
 THE INFORMATION CONTAINED IN THIS DRAWING IS THE SOLE PROPERTY OF <INSERT COMPANY NAME HERE>. ANY REPRODUCTION IN PART OR AS A WHOLE WITHOUT THE WRITTEN PERMISSION OF <INSERT COMPANY NAME HERE> IS PROHIBITED.

		UNLESS OTHERWISE SPECIFIED:		NAME	DATE
		DIMENSIONS ARE IN INCHES	DRAWN	Lim	03/14
		TOLERANCES:	CHECKED		
		FRACTIONAL \pm	ENG APPR.		
		ANGULAR: MACH \pm BEND \pm	MFG APPR.		
		TWO PLACE DECIMAL \pm	Q.A.		
		THREE PLACE DECIMAL \pm	COMMENTS:		
		INTERPRET GEOMETRIC TOLERANCING PER:			
		MATERIAL			
NEXT ASSY	USED ON	FINISH			
APPLICATION		DO NOT SCALE DRAWING			

TITLE:		
PART NO.9 DETAILS (flattened)		
SIZE	DWG. NO.	REV
A	A01.09b	
SCALE: 1:2	WEIGHT:	SHEET 10 OF 10